

POSSIBLES BAG PATTERN

PATTERN BY
MARJORIE BRISTOL
WILMINGTON, MA
JANUARY 28, 2008

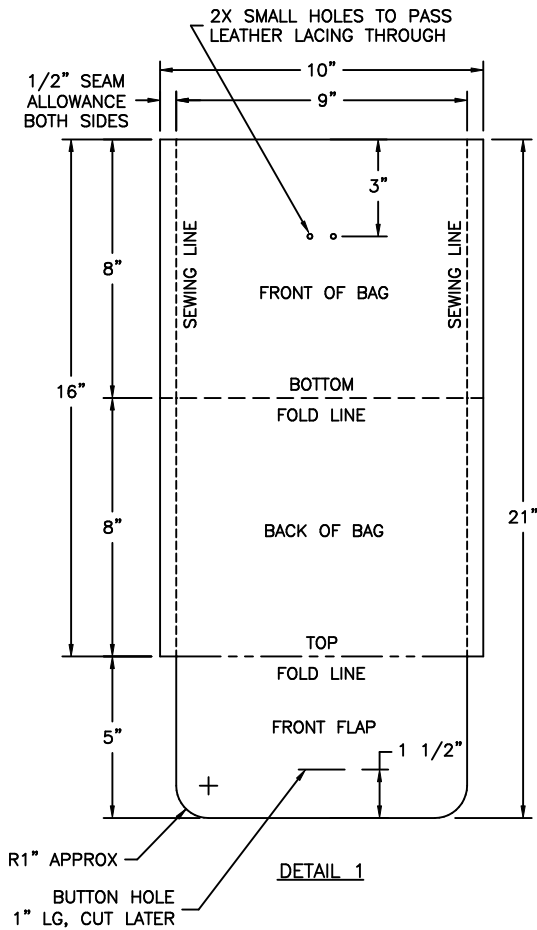

R1" APPROX
BUTTON HOLE
1" LG, CUT LATER

DETAIL 1

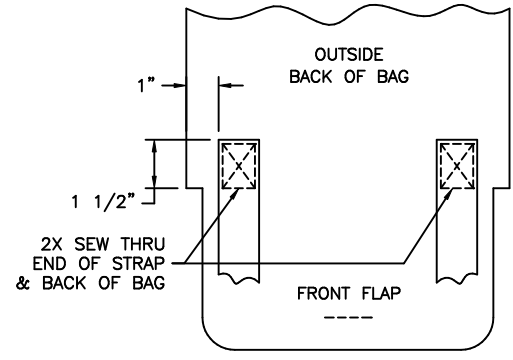

DETAIL 3
SEE NOTE #6

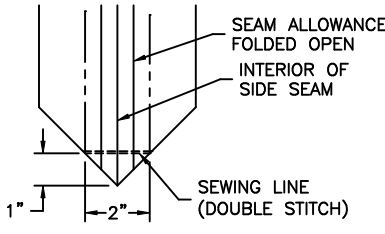

DETAIL 4
ENVELOPE BASE SEAM
DO THIS TO BOTH SIDES
SEE NOTE #9

MATERIAL REQUIRED:

1. CHOOSE A FABRIC THAT IS STURDY AND HEAVY SUCH AS CANVAS, HEAVY TWILL, DENIM, VINYL, ETC. YOU WILL NEED APPROXIMATELY 1/2* YARD OF MATERIAL @ 42" WD. THIS WILL MAKE (2) BAGS.
* GET 3/4 YARD IF A STRAP OF 42" IS NOT LONG ENOUGH TO FIT YOU.

2. (1) 10" PIECES OF LEATHER LACING OR HEAVY SHOE LACE CORD.
3. 2" x 7" STRIP OF CARDBOARD. TRIM TO FIT.
(i.e. CUT FROM A CEREAL BOX WILL DO)
4. LARGE SAFETY PIN TO TURN BELT TO RIGHT SIDE.
5. ACCESS TO A SEWING MACHINE OR HAND SEW WITH NEEDLE & THREAD.

INSTRUCTIONS:

1. MARK FABRIC WITH CHALK OR PENCIL, ON WRONG SIDE OF FABRIC, ACCORDING TO THE DIMENSIONS SHOW IN DETAIL 1. (USE PAPER PATTERN IF AVAILABLE)
2. CUT OUT FABRIC AS ONE WHOLE PIECE AS SHOWN IN DETAIL 1.
3. ACCORDING TO DETAIL 2 CUT SHOULDER STRAP LONG ENOUGH SO THAT WHEN THE BAG IS SLUNG OVER THE LEFT SHOULDER AND ACROSS THE BODY TO HANG THE BAG AT HIP LEVEL ON THE RIGHT SIDE. IF YOU ARE USING 42" FABRIC YOU MIGHT BE LIMITED TO THAT MAXIMUM LENGTH UNLESS YOU BUY EXTRA MATERIAL. IF YOU ARE USING A FABRIC THAT DOESN'T FRAY YOU CAN CUT THIS PIECE 1 1/2" WIDE AND DO WITHOUT THE SEWING STEPS AND SKIP TO STEP 6.
4. FOLD THE 3" WIDE PIECE LENGTH WISE AND SEW A SEAM THE LENGTH OF THE PIECE USING A 1/4" SEAM ALLOWANCE. ANCHOR BOTH ENDS OF STITCHING WITH A BACKSTITCH.
5. ATTACH THE LARGE SAFETY PIN SECURELY TO THE SEAM ALLOWANCE ON ONE END (IN AND OUT THROUGH THE SALVAGE) AND FISH IT THROUGH THE LENGTH TO TURN THE STRAP FROM WRONG TO RIGHT SIDE. PRESS FLAT.
6. ATTACH THE ENDS OF THE STRAP TO THE OUTSIDE BACK OF THE MAIN PIECE ACCORDING TO DIRECTIONS IN DETAIL 3. MAKE SURE THE STRAP IS NOT TWISTED.
7. FOLD BAG PORTION, WITH RIGHT SIDES TOGETHER, ON THE "BOTTOM FOLD LINE". PIN FABRIC TOGETHER ALONG THE TWO SIDES.
8. SEW ALONG SEWING LINE ON TWO SIDES (1/2" SEAM ALLOWANCE). ANCHOR BOTH ENDS BY BACK STITCHING AT START AND FINISH OF SEAM.
9. IRON THE SIDE SEAMS OPEN. STILL WORKING FROM THE INSIDE OF THE BAG, FOLD THE BAG ACCORDING TO INSTRUCTIONS IN DETAIL 4 AND SEW A 2" WIDE SEAM, 1" UP FROM THE POINT ON BOTH SIDES.
10. TURN BAG RIGHT SIDE OUT.
11. INSERT CARDBOARD INTO THE BASE OF THE BAG TO MAKE A FLAT BOTTOM.
12. IF THE FABRIC YOU CHOOSE FRAYS (UNRAVELS EASILY) YOU WILL PROBABLY WANT TO FOLD UNDER THE RAW EDGE OF THE FABRIC ON THE FRONT FLAP AND STITCH IT DOWN.
13. PASS THE LEATHER LACING THROUGH THE TWO SMALL HOLES IN THE BAG FRONT AND TIE THE ENDS IN A KNOT ON THE OUTSIDE OF THE BAG. THIS MAKES YOUR "BUTTON" WHICH YOU CAN SECURE THROUGH THE SLIT ON THE FRONT FLAP.
14. HAVE FUN MAKING YOUR POSSIBLES BAG.

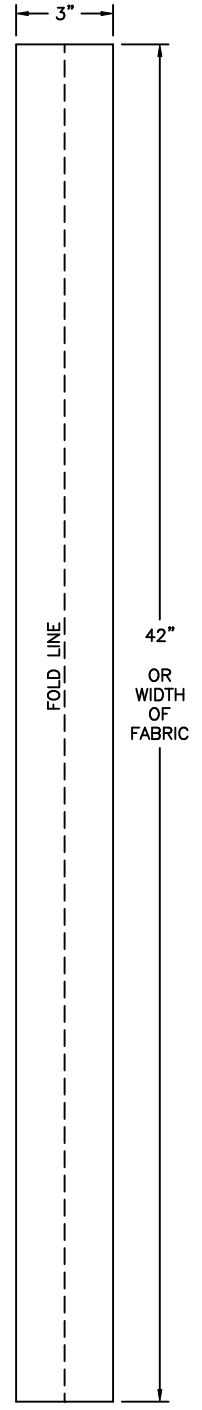

DETAIL 2
SHOULDER STRAP
SEE NOTE #3

THIS PATTERN IS AVAILABLE FOR ANYONE TO USE. I SIMPLY ASK, IF YOU CAN, TO MAKE A TAX DEDUCTABLE DONATION OF \$5.00 TO:
THE INTERNATIONAL RETT SYNDROME FOUNDATION; 4600 DEVITT DRIVE; CINCINNATI, OH 45246.
IF YOU WANT TO KNOW WHAT THIS SYNDROME IS CHECK OUT THEIR WEB SITE AT: www.rettssyndrome.org
THANK YOU, MARJORIE BRISTOL, WILMINGTON, MA